Taxation in Switzerland

Features, Recent Development and Opportunities

Martin Busenhart, Tax Partner

walderwyss attorneys at law

Agenda

- Introduction
- Overview of applicable Swiss tax system
 - Taxation of individuals
 - Taxation of corporations
 - Corporate income and capital tax
 - Swiss withholding tax
 - Stamp duty
- Corporate tax reform III / latest developments
- Old versus new tax incentives
- Relocation of Cyprus Holding Companies to Switzerland

Swiss Business Environment

- Sound economic and political situation
- Excellent infrastructure
- Tax payer friendly environment
- Generic legislation leaving room for interpretation
 - Substance over form (tax avoidance)
 - Ruling practice widely applied
- No detailed domestic transfer pricing rules but faithful application of OECD Guidelines
- No CFC rules / no subject to tax requirements
- Low and further decreasing income and capital tax rates
- EU-like VAT systems with only 8% standard rate
- OECD compliant exchange of information avoid black-listing
- Special tax regimes
- Economic development measures

Overview of applicable Swiss tax system

Individual income tax

- Income taxes are levied on federal, cantonal and communal level and annual wealth taxes on cantonal and communal level (progressive tax rates)
- Ordinary taxation
 - Comparison of 2013 tax burden in selected cantons (maximum tax rates)

Canton	Federal / cantonal / communal tax rate	Tax rate of dividends	Tax base
Luzern	30.6%	100% of ordinary tax rate	50% of dividend income
Nidwalden	25.3%	50% of ordinary tax rate	100% of dividend income
Obwalden	24.1%	100% of ordinary tax rate	50% of dividend income
St. Gallen	32.7%	50% of ordinary tax rate	100% of dividend income
Schaffhausen	32.3%	50% of ordinary tax rate	100% of dividend income
Schwyz	23.6%	25% of ordinary tax rate	100% of dividend income
Thurgau	32.5%	100% of ordinary tax rate	60% / 50% of dividend income
Zug	22.9%	100% of ordinary tax rate	50% of dividend income
Zürich	40.0%	50% of ordinary tax rate	100% of dividend income

Overview of applicable Swiss tax system

Individual income tax

- Lump-sum taxation
 - Taxation based on deemed income and wealth
 - In general income tax base equals five times cost of residence (minimum varies from canton to canton)
 - In general wealth tax base equals hundred times cost of residence (minimum varies from canton to canton)
 - Comparative calculation with income from Swiss source and wealth in Switzerland
 - Under certain double tax treaties modified lump-sum taxation available
 - Limited disclosure
 - Requirements:
 - First time Swiss tax residence or after 10 years absence from Switzerland
 - No gainful activity in Switzerland
 - Upcoming adjustment of the lump sum tax regime
 - Tax base: seven (instead five) times cost of residence
 - Minimal taxable income of CHF 400'000 on federal level
- Possible alternatives
 - Trust
 - Foreign partnerships

Overview of applicable Swiss tax system

Corporate income and capital tax

- Income tax
 - Income taxes are levied on federal, cantonal and communal level
 - The net profit according to the statutory financial statements taking into account tax adjustments (e.g. realization for tax purposes) is the tax base for ordinary taxed companies
 - Tax privileges (e.g. holding, domiciliary and mixed companies, etc.)
 - Restructuring reliefs for mergers, spin-offs, etc.
 - Participation relief for dividends and capital gains provided that participation represents more than 10% in the nominal share capital or has a fair market value of CHF 1 million (only applicable for dividends) and the holding period of 1 year for capital gains is observed
 - Thin capitalization rules
- Capital tax
 - Cantonal/communal tax on net equity (nominal share capital, capital contribution reserves, other reserves and retained earnings) incl. deemed equity (thin capitalization rules)
 - Reduced rates for domiciliary, mixed and holding companies
 - In certain cantons creditable against income tax

Overview of applicable Swiss tax system

Corporate income and capital tax

- Comparison of 2013 tax burden in selected cantons

Canton	Income tax (ordinary taxed)	Income tax (holding company)	Income tax (mixed company)*	Capital tax (ordinary taxed)	Capital tax (holding company)	Capital tax (mixed company)
Luzern	12.20%	7.83%	8.74%	0.1800%	0.0036%	0.0036%
Nidwalden	12.66%	7.83%	8.84%	0.0100%	0.0100%	0.0100%
Obwalden	12.66%	7.83%	8.84%	0.2000%	0.0010%	0.0010%
St. Gallen	17.40%	7.83%	9.92%	0.0680%	0.0034%	0.0034%
Schaffhausen	15.97%	7.83%	9.58%	0.2100%	0.0053%	0.0053%
Schwyz	14.28%	7.83%	9.20%	0.1452%	0.0091%	0.0091%
Thurgau	16.43%	7.83%	9.69%	0.0837%	0.0028%	0.0028%
Zug	14.90%	7.83%	9.33%	0.0748%	0.0030%	0.0150%
Zürich	21.15%	7.83%	10.84%	0.1718%	0.0344%	0.0344%

* taxable quota of 20%

Overview of applicable Swiss tax system

Swiss withholding tax and stamp duty

- Swiss withholding tax
 - 35% WHT on all dividend distributions including liquidation proceeds
 - Reduction by applicable double tax treaty (0% or 5% under most treaties)
 - No WHT on the distribution of capital contribution reserves (if accounted for separately)
 - No WHT on royalties
 - Basically no WHT on interest
 - Treaty anti-abuse provisions
- One-time capital duty
 - 1% on the issuance of shares by, and capital contributions to Swiss corporation in excess of CHF 1 million
 - Restructuring reliefs available
- Securities transfer tax
 - Transfer of taxable securities is subject to securities transfer tax if taxable securities are transferred against consideration and at least one of the parties or intermediaries qualify as Swiss securities dealer
 - 0.15% for Swiss securities and 0.3% for foreign securities
 - Restructuring reliefs available

Corporate tax reform III / latest developments

- CTR III was initiated in 2008 by the Swiss Federal Council
- CTR III focuses on improving the position of Switzerland in the international tax competition
- Possible measures of the reform are:
 - Modification or abolition of the cantonal tax privileges such as the mixed company regime
 - Improvement of the participation exemption (no minimum threshold of 10% share capital)
 - Abolition of the issuance stamp tax on equity
 - Elimination of fiscal barriers of group financing
 - Option of waiving capital tax at a cantonal level
 - Extension of the tax loss carry forwards (e.g. possibility to include losses of subsidiaries)

Corporate tax reform III / latest developments

- According to the press conference of May 17, 2013 the following suggestions and measures could be applied related to the increasing pressure on the Swiss tax privileges:
 - Introduction of compliant tax regimes (i.e. equal treatment of domestic and foreign source income)
 - Innovation or license box regime
 - Deemed interest deduction on equity
 - No loop holes for international non taxation
 - Justifiable from a tax systematic point of view or introduced in at least in one EU member state

Old versus new tax incentives

Existing tax privileges

- **Holding company status**
 - No cantonal/communal income tax
 - For federal income tax, participation relief applies
 - Reduced capital tax
 - Requirements:
 - 2/3 of assets or income derived from participations
 - Only minor business activities in Switzerland
 - Challenged by the EU

Old versus new tax incentives

Existing tax privileges

- **Mixed company status**

- 5% to 20% of foreign source income is subject to cantonal/communal income tax
- Swiss source income is ordinary taxed
- Income from participation is exempt
- Reduced capital tax
- Requirements:
 - 80% of income derives from foreign source and 80% of the expenses are paid to abroad
- Challenged by the EU

Old versus new tax incentives

New tax regime

- **Licence box regime** (already implemented in the Canton of Nidwalden)
 - Net licence income: Costs that are linked to the IP are deductible (taxes, administrative costs, depreciation etc.)
 - Net licensing income from Swiss and foreign sources from the right to use IP will be taxed separately at 20% of the ordinary cantonal and communal income tax rate
 - Cantonal and communal income tax rate of 1.2% on net license income; i.e. the effective corporate tax rate (including federal tax) is 8.8%
 - Requirements:
 - Only applicable upon request for companies having their domicile or branch in the canton of Nidwalden
 - Appropriate substance (offices, qualified personal, management etc.) is required
 - Not compatible with holding or mixed company regime

Old versus new tax incentives

New tax regime

- **Licence box regime** (already implemented in the Canton of Nidwalden)
 - Benefits compared to mixed company regime:
 - No distinction between Swiss and foreign source income (EU has criticised the mixed company regime for giving unfair advantage to foreign companies)
 - Active company which is considered as an ordinarily taxed entity
 - Established fiscal practice applied in other European countries (e.g. Netherlands, Spain, Luxembourg, France, UK (in total 12 EU-States))
 - In line with the OECD-Standards

Relocation of Holding Companies from Cyprus to Switzerland

Current structure:

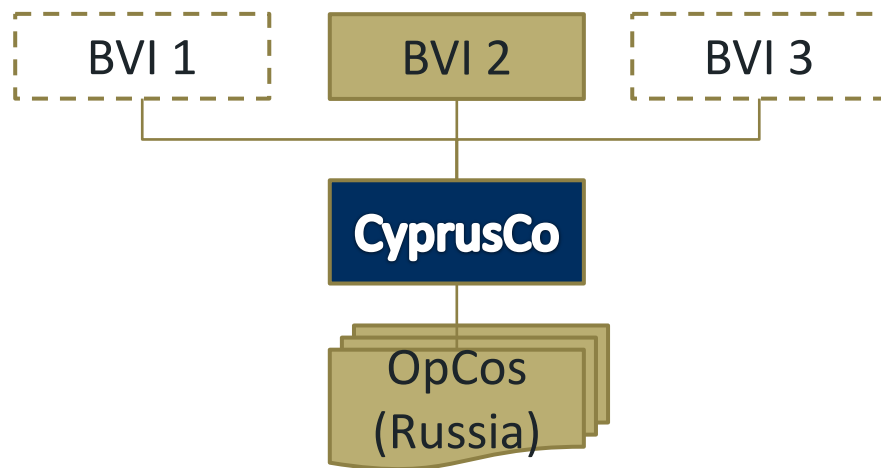

Target structure:

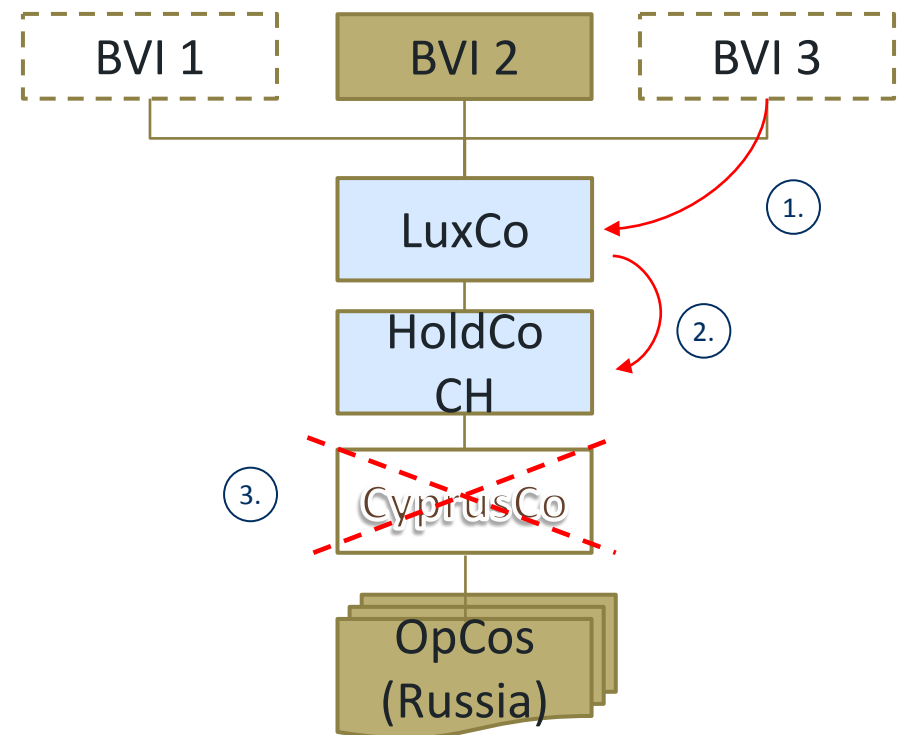

Restructuring steps:

- Step 1 : Establishment of LuxCo
- Step 2: Establishment of Swiss HoldCo
- Step 3: Liquidation of CyprusCo

Relocation of Holding Companies from Cyprus to Switzerland

- Swiss corporate income tax
 - Holding company or mixed company status should apply on cantonal/communal level
 - Participation relief should apply on the federal level
 - Step-up of the base costs to the fair market value
- Stamp duty
 - No one-time capital duty consequences on the establishment of HoldCo (reorganisation exemption)
 - Qualification of HoldCo as Swiss securities dealer after 6 months of the end of the first financial year

Relocation of Holding Companies from Cyprus to Switzerland

- Russian WHT on dividends paid by OpCos (Russia) to HoldCo CH:
 - Under the double taxation treaty between Switzerland and Russia the WHT on dividends is reduced to 5% with respect to qualifying participations of at least 20% or participations of a value of at least CHF 200,000 (or the equivalent amount in another currency). The same rate would apply under the Dutch-Russian double taxation treaty
- Swiss WHT on dividends paid by HoldCo CH to LuxCo:
 - The paid in capital derived from the contribution of CyprusCo at fair market value should qualify as capital contribution reserves and can be re-distributed without any Swiss WHT consequences
 - In order to make future dividend distributions without triggering the 35% Swiss dividend WHT, LuxCo must be eligible for the benefits of the Swiss-Luxembourg double tax treaty and/or the Savings Agreement entered with the EU. In order to qualify for treaty relief (0% rate will apply), LuxCo needs to be adequately equity financed (equity of at least 30% of value of participations held) and needs to meet a number of criteria including minimal substance in Luxembourg (LuxCo not being a mere conduit and having a commercial rationale beyond the reduction of Swiss WHT, e.g., as a personal holding company or a common investment platform for several investors)

Relocation of Holding Companies from Cyprus to Switzerland

- Overall comparison to a Dutch holding company
 - No substantial tax disadvantages of Swiss holding company compared Dutch holding company if ruling is granted by the Swiss federal tax administration (i) on the reduction of the Swiss dividend WHT and (ii) on the exemption from Swiss stamp duty
 - Potential tax advantages of a Swiss holding company compared to a Dutch holding company for IP and finance related group tax planning
 - Potential non-tax advantages of a Swiss holding company compared to a Dutch holding company due to the fact that Switzerland is not part of the EU and the EURO zone. Switzerland is politically stable and has balanced public finances and a prosperous economy including a strong, sound and stable banking system (nearly double of capital requirements under Basel III framework apply on Swiss banks)

Martin Busenhart

Martin Busenhart, Partner
Direct line: +41 44 498 95 80
martin.busenhart@walderwyss.com



Walder Wyss

Zurich

Walder Wyss Ltd.
Seefeldstrasse 123
P.O. Box 1236
8034 Zürich
Switzerland

Phone: +41 44 498 98 98
Fax: +41 44 498 98 99
reception@walderwyss.com
www.walderwyss.com

Berne

Walder Wyss AG
Bubenbergplatz 8
P.O. Box 8750
3001 Bern
Switzerland

Phone: +41 44 498 98 98
Fax: +41 44 498 98 99
reception@walderwyss.com
www.walderwyss.com



walderwyss attorneys at law